



our **power**, your **passion**

# SIRIUS 700

**I** MANUALE USO E MANUTENZIONE

**GB** OPERATOR'S INSTRUCTION BOOK





**Italiano** ISTRUZIONI ORIGINALI **5**

**English** TRANSLATION OF ORIGINAL INSTRUCTIONS **43**



## Function keys and menu items



Item	Name	Item	Name
1	HOME key	6	START/PAUSE key
2	LCD display	7	Multifunction key right
3	STOP key	8	Multifunction key left
4	Up arrow key	9	ON/OFF key
5	Down arrow key	10	Menu key

- Refer to the specified pages for information about calling up the various menu items and for the descriptions of them.

Chapter/page
„Start-up“ see page 58
„Setting the time“ see page 67
„Setting the date“ see page 67
„Setting the language“ see page 68
„Enter PIN code“ see page 59
„Changing the PIN code“ see page 59
„Activate or deactivate the button tones“ see page 68
„Changing the display contrast on the LCD display“ see page 69
„Restoring factory settings“ see page 69
„Setting the week program“ see page 66

# 1 Scope of supply

## 1.1 Unpacking the machine

- Carefully unpack the robot lawnmower and its components and check everything for damage in transport. If there is any transport damage, immediately notify your dealer.
- If the robot lawnmower was sent by a parcel service, retain the original packaging and accompanying documents.

## 1.2 Scope of supply

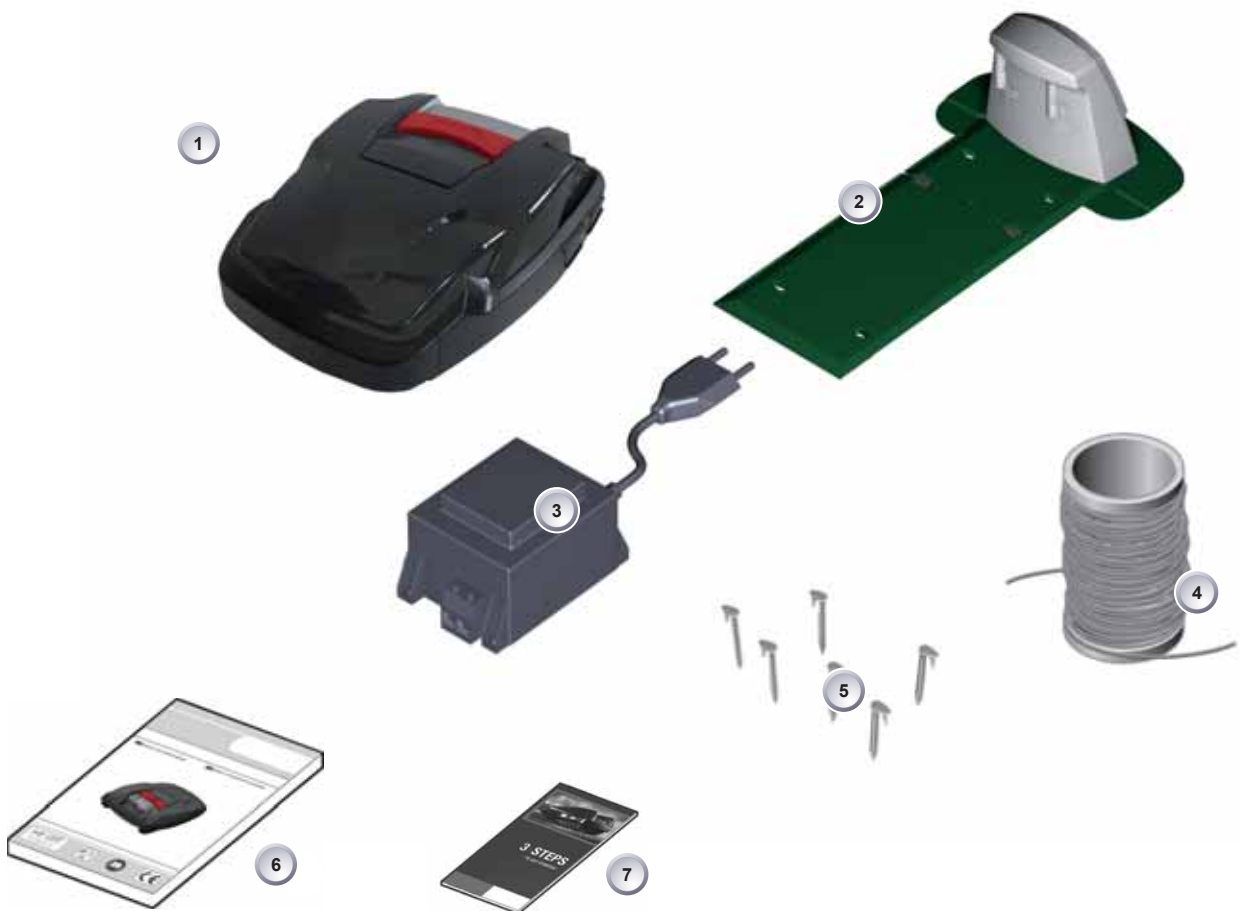

Item	Name	Item	Name
1	Robot lawnmower	5	Lawn pegs (100 pcs.)
2	Base station	6	Instructions for use
3	Transformer	7	Quickstart guide
4	Boundary cable (100 m)		

---

## Contents

<b>1</b>	<b>Scope of supply</b> .....	<b>44</b>
1.1	Unpacking the machine .....	44
1.2	Scope of supply .....	44
<b>2</b>	<b>About this product</b> .....	<b>48</b>
2.1	Designated use .....	48
2.2	Prohibited use .....	48
<b>3</b>	<b>Safety notes</b> .....	<b>48</b>
3.1	Explanation of symbols .....	48
3.2	General safety notes .....	49
3.3	Safety notes for operation .....	49
<b>4</b>	<b>Product information</b> .....	<b>50</b>
4.1	Product description .....	50
4.2	Description of function .....	50
4.3	Control panel .....	51
4.4	Sensors in the robot lawnmower .....	51
4.5	Base station .....	52
4.6	Transformer .....	52
4.7	Boundary cable .....	52
<b>5</b>	<b>Assembly/installation</b> .....	<b>53</b>
5.1	Assembling the base station .....	53
5.2	Setting up the base station .....	53
5.3	Laying the boundary cable .....	54
5.4	Laying options .....	55
5.5	Laying the cable around obstacles .....	56
5.6	Connecting the boundary cable to the base station .....	56
5.7	Connecting the low-voltage cables to the transformer .....	56
5.8	Opening the cover on the rear of the base station .....	57
5.9	Checking the connection .....	57

<b>6</b>	<b>Start-up</b> .....	<b>58</b>
6.1	Preparations .....	58
6.2	Switching on/status display .....	58
6.3	Language selection .....	58
6.4	Enter PIN code .....	59
6.5	Changing the PIN code.....	59
6.6	Setting/changing the date .....	59
6.7	Setting/changing the time .....	60
6.8	Calibration .....	60
6.9	Starting the robot lawnmower.....	61
<b>7</b>	<b>Mowing</b> .....	<b>62</b>
7.1	Mowing tips .....	62
7.2	Setting the cutting height.....	62
7.3	Charging the battery in the robot lawnmower .....	62
7.4	Exhaustively discharged battery.....	63
<b>8</b>	<b>Programming</b> .....	<b>64</b>
8.1	Starting the robot lawnmower.....	64
8.2	Overview .....	65
<b>9</b>	<b>Program menu</b> .....	<b>66</b>
9.1	Setting the week program.....	66
<b>10</b>	<b>Setting menu</b> .....	<b>67</b>
10.1	Setting the time .....	67
10.2	Setting the date .....	67
10.3	Setting the language .....	68
10.4	Further setting possibilities.....	68
10.5	Activate or deactivate the button tones .....	68
10.6	Changing the display contrast on the LCD display.....	69
10.7	Restoring factory settings.....	69



---

<b>11</b>	<b>Information menu</b> .....	<b>69</b>
11.1	Hardware information .....	69
11.2	Software information.....	70
<b>12</b>	<b>Program information</b> .....	<b>70</b>
<b>13</b>	<b>Transport</b> .....	<b>70</b>
<b>14</b>	<b>Maintenance</b> .....	<b>71</b>
14.1	Check the rollers can move freely.....	71
14.2	Checking/cleaning contacts .....	71
14.3	Checking/cleaning the base station .....	72
14.4	Cleaning the chassis.....	72
<b>15</b>	<b>Repair</b> .....	<b>72</b>
15.1	Renewing the cutting blade plate.....	72
<b>16</b>	<b>Technical data</b> .....	<b>73</b>
<b>17</b>	<b>Help in case of malfunctions</b> .....	<b>74</b>
17.1	Examples of fault messages .....	74
17.2	Troubleshooting.....	75
17.3	Interactive help .....	78
<b>18</b>	<b>Warranty</b> .....	<b>78</b>
<b>19</b>	<b>Disposal</b> .....	<b>79</b>
<b>20</b>	<b>Declaration of conformity</b> .....	<b>79</b>

---

## 2 About this product

- Comply with the safety and warning instructions in these instructions for use, and on the robot lawnmower.
- These instructions for use are a permanent component of the described product, and should remain with the machine if it is sold to someone else.
- Only experienced persons who are familiar with the operation and safe use of this machine should use it. Give other users the manual with operating instructions, which they should read before using.

### 2.1 Designated use

- The robot lawnmower is exclusively intended for mowing private lawns.
- Any other use is regarded as not in accordance with the designated use.

### 2.2 Prohibited use

1. The robot lawnmower is not suitable for use in commercial enterprises, public facilities, parks, sports facilities or in agriculture and forestry.
2. The robot lawnmower must not be used for cutting other materials, particularly materials above ground level that require the lawnmower to be raised above the ground.
3. The robot lawnmower must not be used to shred branches, nor materials thicker than grass.
4. The robot lawnmower must never be used to transport, push or tow trailers or other similar objects.
5. It is prohibited to fit implements or accessories other than those supplied by the manufacturer.

## 3 Safety notes

### 3.1 Explanation of symbols

The following safety notes are used in these instructions for use. The signal word used depends on the particular risk.



#### Warning!

**Warning about a potential danger that could lead to serious or fatal injuries.**



#### Caution!

**A dangerous situation that could lead to injury.**



#### Important

**A dangerous situation that could lead to damage to the machine.**

#### Note!

Explanatory description that is useful for understanding the work or the operating procedure to be carried out.

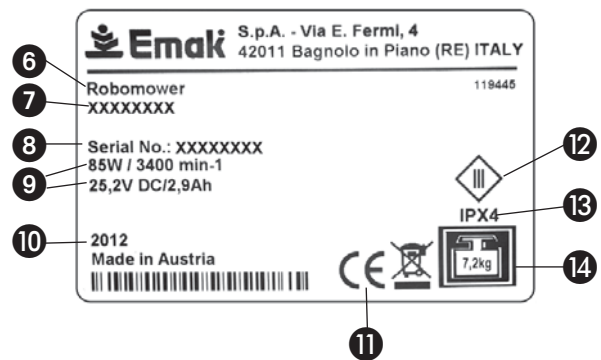
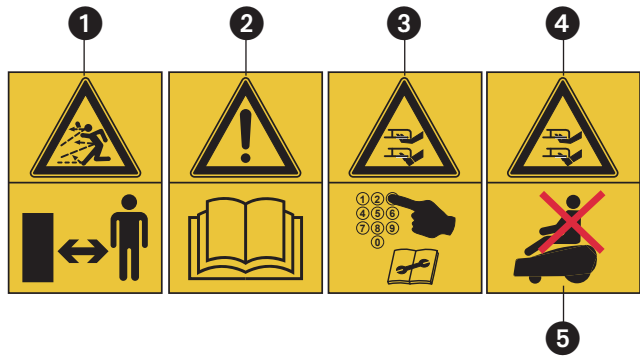

- 1 - **WARNING!** - Do not let anybody approach to the working area. Be careful of thrown objects
- 2 - Read operator's instruction book before operating this machine.
- 3 - **Be careful of the cutter blades** when adjusting or servicing the machine.
- 4 - **Be careful of the cutter blades** when operating the machine.
- 5 - **DO NOT** stand on the robotic lawn mower.
- 6 - Type of machine: **ROBOT LAWNMOWER**
- 7 - Machine brand and model
- 8 - Serial number
- 9 - Specifications
- 10 - Year of manufacture
- 11 - CE conformity marking
- 12 - Class 3 appliance.
- 13 - Protection class of the machine.
- 14 - Weight of the machine.

## Safety devices

- Safety devices are not allowed to be bypassed, manipulated or removed. Failure to comply can endanger your own health and that of other people.
- The robot lawnmower is protected by a PIN code in order to prevent it from being switched back on inadvertently or without authorisation.
- The robot lawnmower is supplied from the factory with the PIN code 0000.
- A PUK code must be entered if the PIN code is entered incorrectly three times. Request this from your dealer.
- The robot lawnmower is equipped with a safety sensor. If the robot lawnmower is lifted up, its motor and cutting blades are stopped within 2 seconds.
- After contact with an obstacle, the robot lawnmower moves back, stops and changes its direction of travel.

### 3.2 General safety notes

The owner is responsible for accidents involving other people and their property.



#### Caution!

##### Danger of injury.

- Do not deactivate safety and protective devices.

- The robot lawnmower is not allowed to be operated by anyone who has not mastered safe handling of the robot lawnmower and/or has not read and understood the instructions for use.
- During mowing, make sure that no-one places any part of their body in the vicinity of the rotating cutting blades.
- If the robot lawnmower is defective, e.g. on its cutting blade(s), cable or base station, then do not take it into operation.
- Have the defects repaired proficiently.



#### Warning!

**Take maximum care to ensure that children and animals are never allowed near the machine.**

**Do not allow children to play with the device**

### 3.3 Safety notes for operation



#### Warning!

**Switching on inadvertently or unauthorised use can lead to extremely serious injuries.**

- The robot lawnmower must be switched off and secured with a PIN code.

#### Note!

- Keep the PIN code and PUK code where they cannot be accessed by unauthorised people.
- The PIN code can be changed by the owner.
- If the PIN code is entered incorrectly three times, it will be necessary to enter a PUK code.
- If the incorrect PUK code is entered you must wait 24 hours before making a repeat attempt.

- Regularly check the robot lawnmower and the base station for damage.
- The replacement or repair of damaged components and batteries should be entrusted to specialist workshops approved by the manufacturer.

#### Note!

- Never carry out operations or repairs on your own that are other than routine maintenance. Call specialised and authorised workshops only.

## 4 Product information

### 4.1 Product description



- 1 Control panel
- 2 Carry handle
- 3 Charging contacts
- 4 Bumper
- 5 Housing
- 6 Cover plate (flap for height adjustment)
- 7 Height adjustment interior
- 8 STOP key
- 9 Front wheels
- 10 Blade plate
- 11 Drive wheels with high-grip tread
- 12/13 Cutter/clearer blades

### 4.2 Description of function

- The robot lawnmower is a fully automatic, battery-operated lawnmower which moves freely within a defined mowing area.
- The mowing area is defined by a boundary cable that is connected to the base station.
- In order for its battery to be recharged, the robot lawnmower moves along the boundary cable into the base station.
- Mowing programs are pre-installed for normal mowing, and also include the lawn and edge mowing function. These mowing programs can be changed.
- The special arrangement of blades means that the mown grass is not gathered up but remains on the lawn between the stalks of grass. As a result, it has a mulching or fertilising effect.

### 4.3 Control panel



- |   |                |    |                         |
|---|----------------|----|-------------------------|
| 1 | HOME key       | 6  | START/PAUSE key         |
| 2 | LCD display    | 7  | Multifunction key right |
| 3 | STOP key       | 8  | Multifunction key left  |
| 4 | Up arrow key   | 9  | ON/OFF key              |
| 5 | Down arrow key | 10 | Menu key                |

#### ■ Function of the keys

- The [HOME key] (1) cancels the current mowing procedure. The robot lawnmower returns to the base station and will restart with the first programmed operation for the next day.
- The [LCD display] (2) displays the current status or the selected menu.
- Pressing the [STOP key] (3) stops the robot lawnmower and the cutting blade within 2 seconds.
- The [up arrow key] (4) and [down arrow key] (5) are used for navigating in the menu and for changing values.
- Press the [START/PAUSE key] (6) to start the robot lawnmower or interrupt operation. If you press START/PAUSE during programmed operation the robot will restart automatically after approximately 2 minutes.
- Use the [multifunction keys right or left] (7) or (8) to confirm or revoke commands, for example (selecting a menu command).
- The [ON/OFF key] (9) is used for switching the robot lawnmower on or off.
- Press the [menu key] (10) to open the menu.

### 4.4 Sensors in the robot lawnmower

#### Bump sensors and obstacle detection



- The robot lawnmower is equipped with sensors that ensure it changes its direction of travel if it encounters obstacles. When it encounters an obstacle, the top part of the housing (1) is shifted slightly. This causes a sensor to trigger a change in the direction of travel.
- If the robot lawnmower is lifted up by its carry handle during operation, a safety sensor stops the blade within 2 seconds and switches off travel mode.

#### Note!

The robot lawnmower does not restart automatically after being switched off by a safety sensor. To restart, it is necessary to acknowledge the fault by pressing the multifunction key and rectifying the fault.

### Travel direction anti-tipping sensor

> 35 %

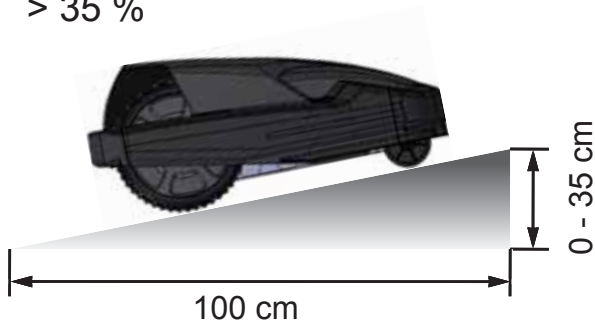

- The robot lawnmower is switched off by the tilt sensor if it encounters an upward or downward slope of more than 35%.

### Sideways anti-tipping sensor

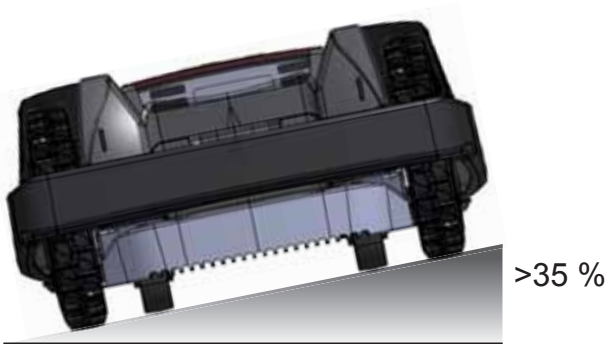

- The robot lawnmower is switched off by the tilt sensor if it encounters sideways slopes of more than 35%.

### 4.5 Base station

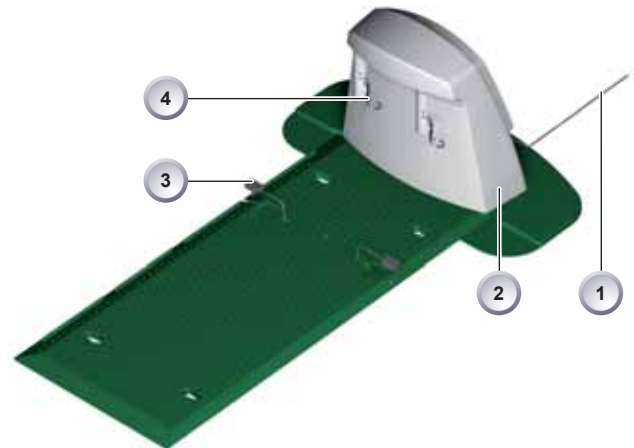

- The base station (2) is connected to the electrical power supply (transformer) using the low-voltage cable (1).
- The base station (2) generates a control signal and sends this in the boundary cable (3).
- There are two charging contacts (2) on the base station (4) which contact the charging contacts on the robot lawnmower as soon as it moves into the base station (2).

### 4.6 Transformer



#### Important

##### Damage due to splash water

Set up the transformer in a dry place where it is protected against splash water.

### 4.7 Boundary cable



#### Important

##### Damage to the boundary cable

Do not scarify the lawn in the area on either side of where the boundary cable is laid.

- The boundary cable is secured with lawn pegs. If the supplied boundary cable is not large enough for your lawn, you can obtain an extension cable from your dealer.



## 5 Assembly/installation

### 5.1 Assembling the base station

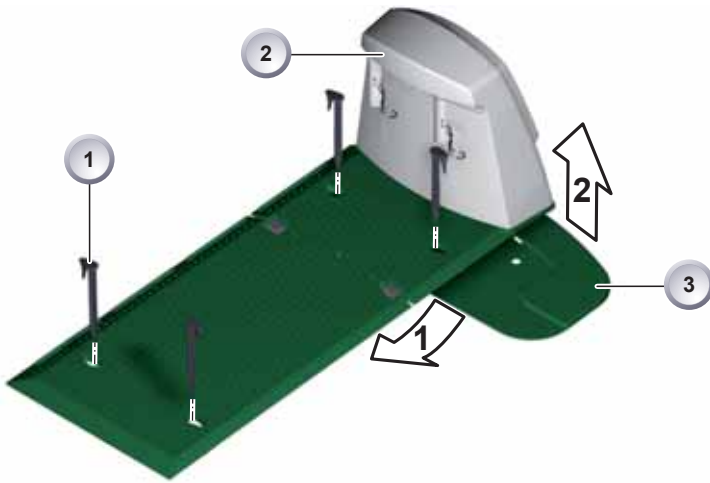

- Insert the base plate (3) with its front edge in the direction of arrow 1 into the plate of the base station (2), and fold upwards in the direction of arrow 2. Secure the base station to the ground with the pegs (1).

### 5.2 Setting up the base station

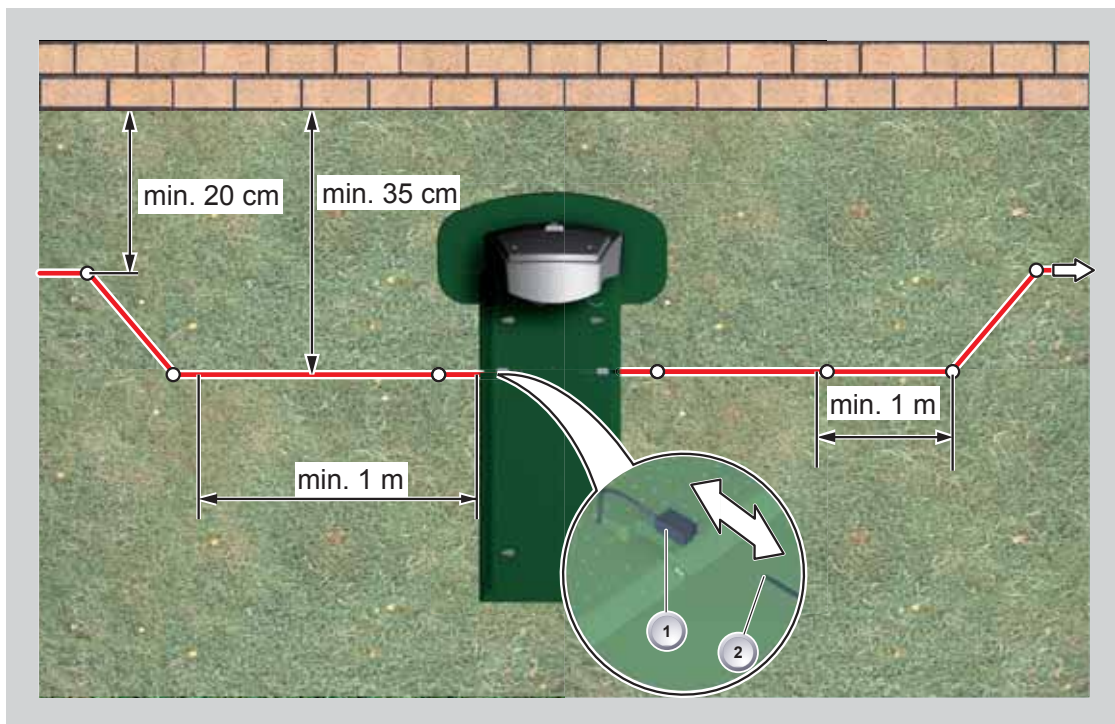

- Place the base station in a shady location in the garden on smooth level ground where it will be protected against the rain. Then use lawn pegs to secure it in place (white dots). Comply with the specified dimensions when doing this.
- Remove the insulation from the boundary cable (2) and connect it to one side (1) of the base station. Then continue to lay the cable as shown, complying with the specified distances.
- To avoid damage when mowing, make sure that the boundary cable (2) is in direct contact with the ground at all points when you are laying it. If there are places where the boundary cable (2) is not in direct contact with the ground, secure these with an additional lawn peg.

### 5.3 Laying the boundary cable



#### Important!

**Danger of damage to the boundary cable and impairment of function of the robot lawnmower!**

To ensure reliable function, the boundary cable must be laid as described in the following steps:

- Check the area to be mown.
- Remove mole hills and windfall fruit, and level out any holes in the area to be mown. Lay your boundary cable around obstacles.
- Lawns with grass more than 8 cm tall cannot be mown using the robot lawnmower, and will have to be mown in advance before the boundary cable is laid.
- Once the boundary cable has been laid **on the grass**, do not scarify the area of the boundary cable any longer.

#### Laying options

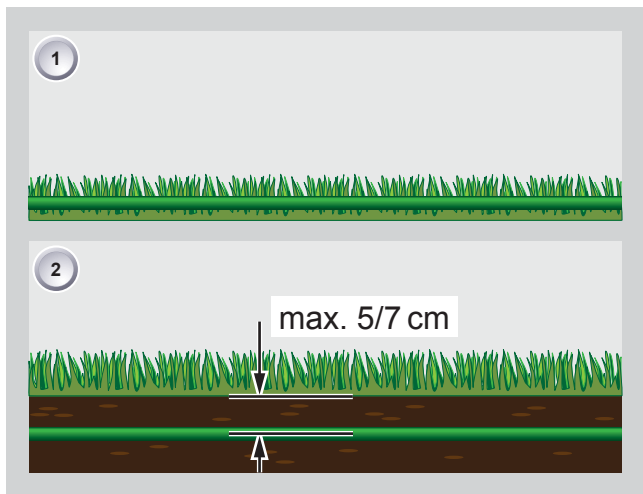

- The boundary cable can be laid on the lawn (1) and as much as 5/7 cm under the turf (2). Have your dealer carry out the laying under the turf on your behalf.
- If necessary, you can also combine both methods.

#### Spare loops of cable

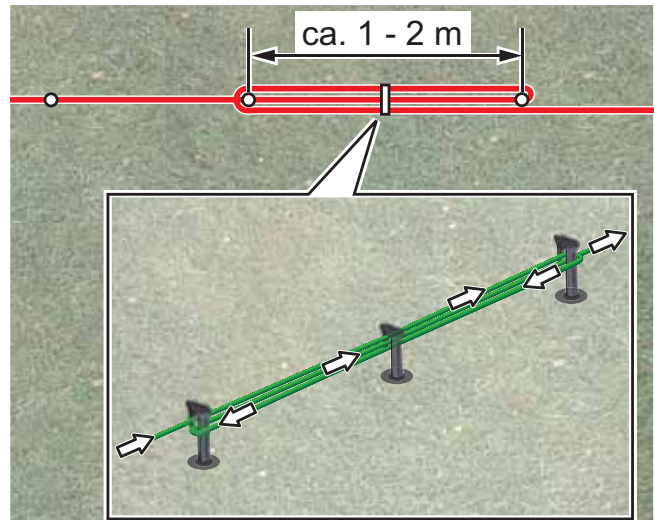

- You should incorporate spare loops of cable at regular intervals in order to allow the base station to be repositioned or the mowing area to be extended even after the mowing area has been laid out. To do this, guide the boundary cable around a lawn peg, return to the previous lawn peg, then continue as shown, securing with another lawn peg.
- Select the number of spare cable loops according to your own judgement.



## 5.4 Laying options

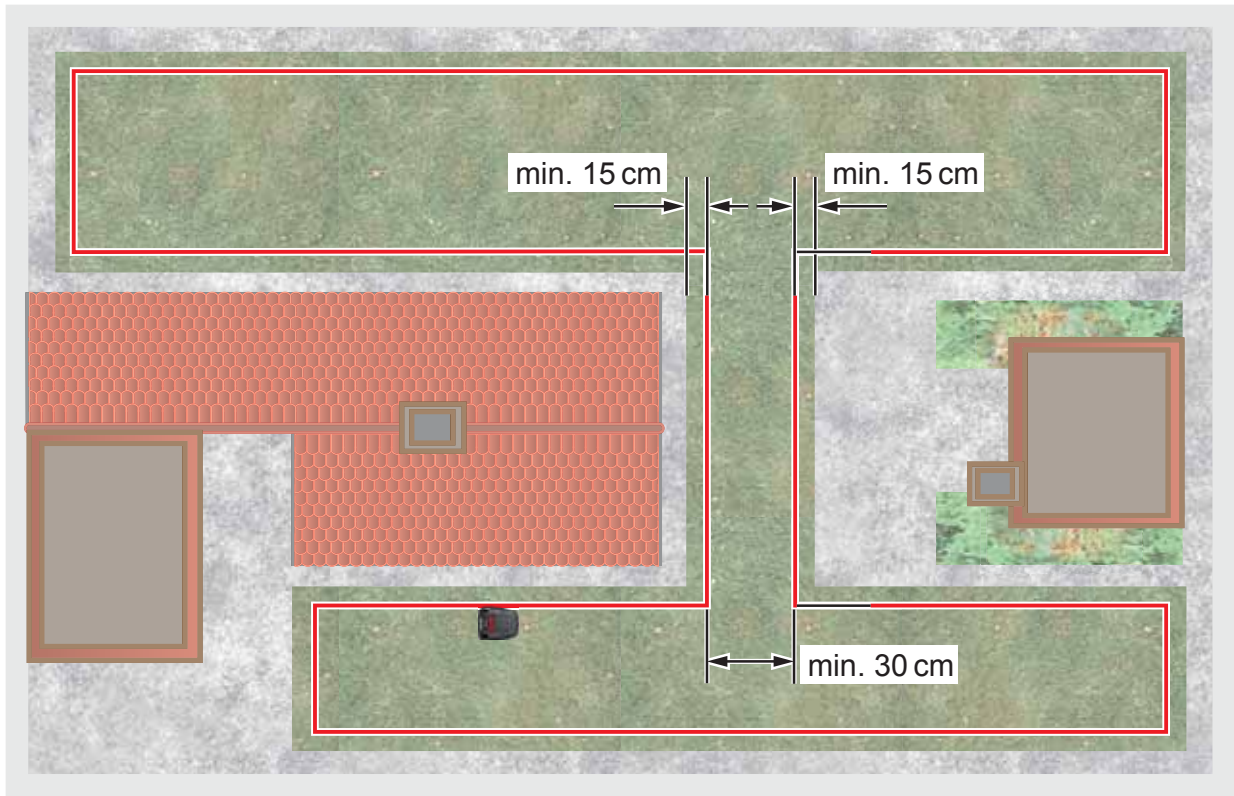

- When laying the boundary cable in walkways, it is necessary to maintain the minimum distances from obstacles and the minimum passage width, otherwise the robot lawnmower will not be able to operate correctly.

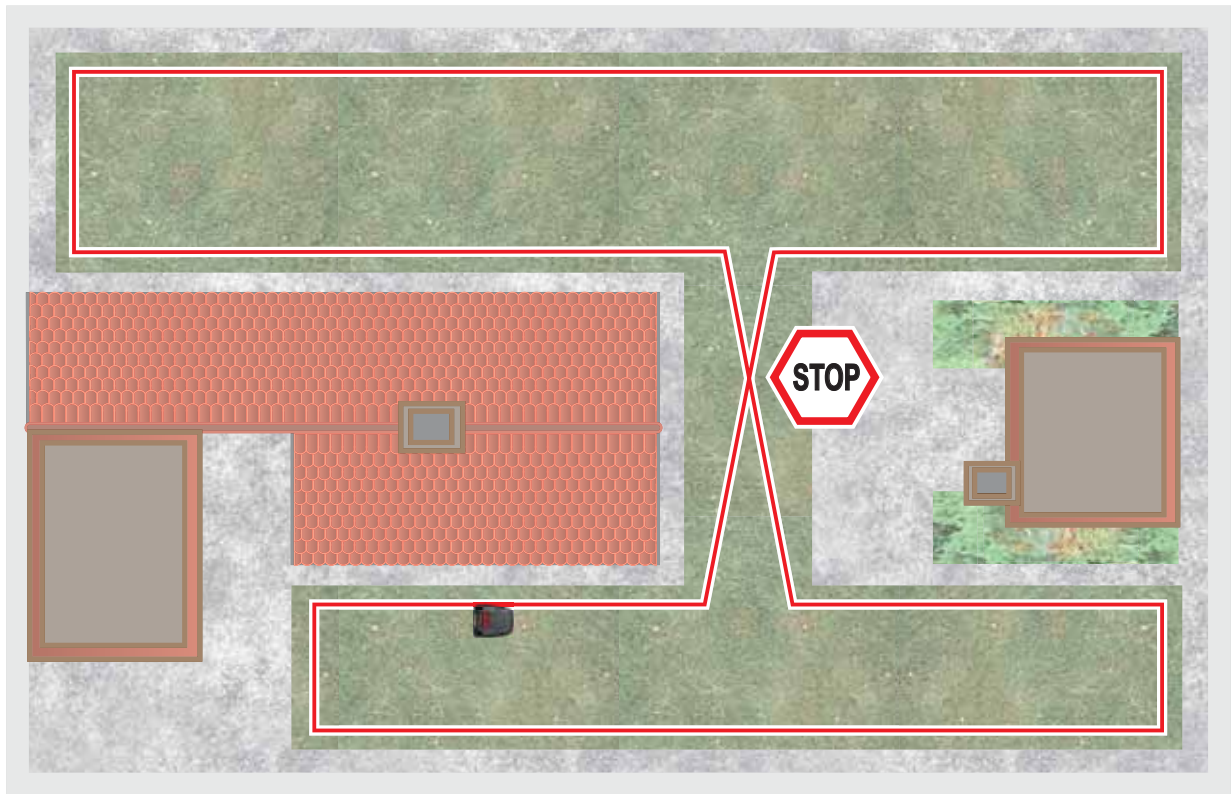

- If there is a crossover in the boundary cable layout this will cause operating faults because the system will be unable to distinguish between the internal and external sides of the boundary.

### 5.5 Laying the cable around obstacles

- When laying the cable around obstacles, maintain the distances shown in the illustration.

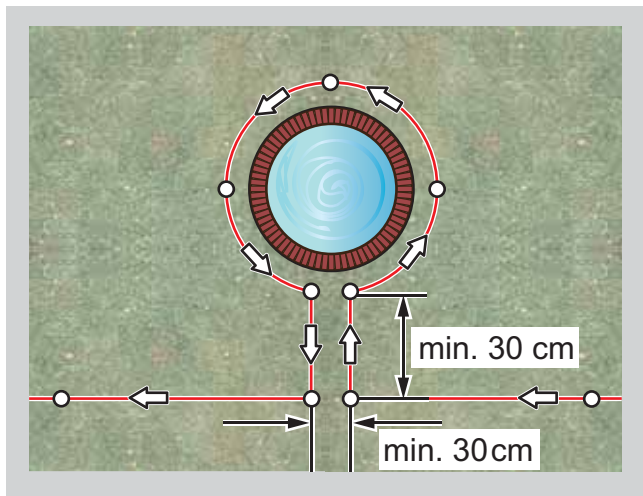

- When the distance is at least 30 cm, the robot lawnmower interprets the distance as a path and moves around the obstacle.

#### Note!

If there is a distance of 0 cm between the cables, it is possible for the cable to be driven over.

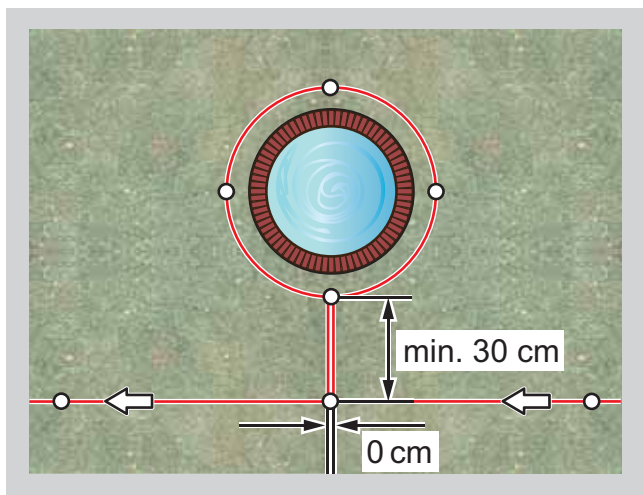

### 5.6 Connecting the boundary cable to the base station

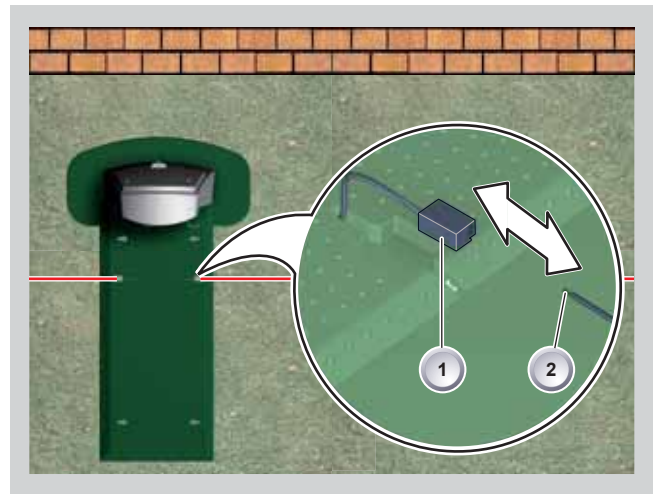

- Remove the insulation from the boundary cable (2) after laying the cable and connect to the spring terminals (1).

### 5.7 Connecting the low-voltage cables to the transformer

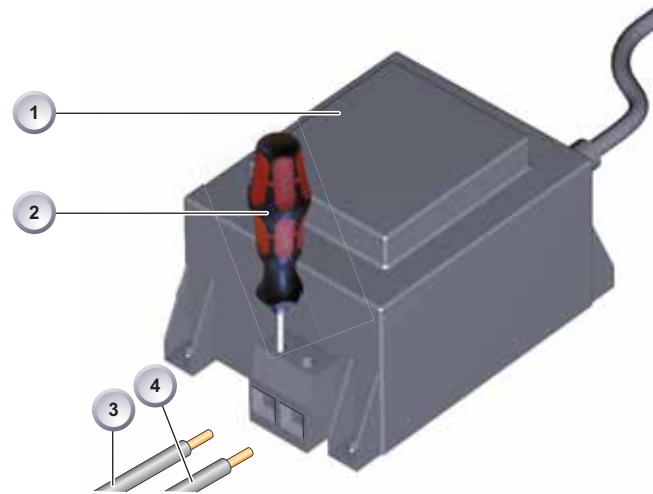

- Strip 10 mm of insulation off the low-voltage cables (3) and (4).
- Unscrew the screws with a screwdriver (2) and connect the low-voltage cables (3) and (4) to the transformer (1).
- The cables can be connected to either terminal, there is no need to observe a particular polarity.
- Insert the mains plug of the transformer into the mains socket.

## 5.8 Opening the cover on the rear of the base station

### Note!

The cover only has to be opened for the purpose of checking the LED displays.

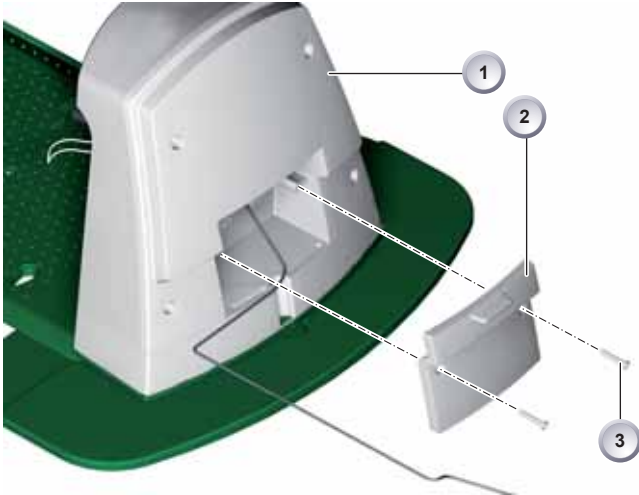

- To check the connection, unscrew the fastening screws (3) and remove the cover (2) from the base station (1).

## 5.9 Checking the connection

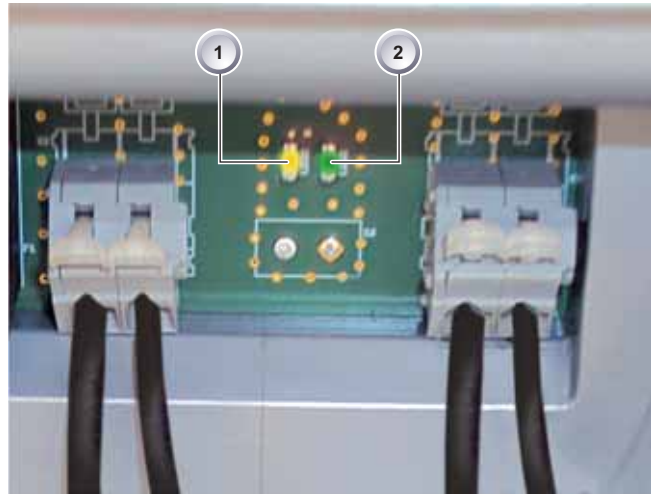

### Important! Damage to the cables.

The LEDs must light up when the cables are connected. If this is not the case, pull out the mains plug and check if all plug connections and cables are correctly seated; also check them for damage.

The yellow LED (1):

- lights up if the base station is connected to the transformer and there is an electrical power supply to the transformer.
- flashes when the robot lawnmower is charging.

The green LED (2):

- lights up when the boundary cable is laid correctly and the loop is OK.
- The green LED flashes and then goes out if the loop of the boundary cable is not OK.

## 6 Start-up

### 6.1 Preparations

#### Note!

Before starting to operate the robot lawnmower, place it in its starting position in the defined mowing area. Please comply with the information on transporting the robot lawnmower on 70.

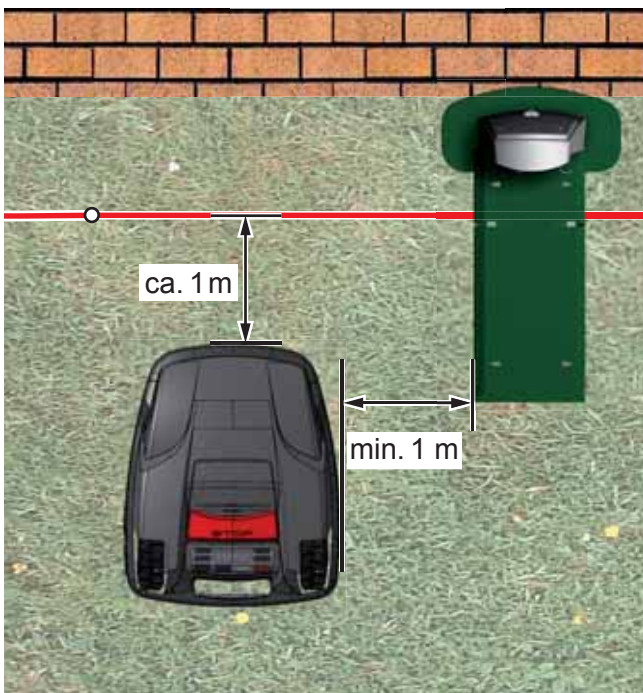

- Comply with the specified dimensions.

### 6.2 Switching on/status display

- Switch on the robot lawnmower by pressing the [ON/OFF key].
- The LCD display then shows the illustrated information:

```

Emak
Robomower
Software # xxxxxxxxx
SN: xxxxxxxxxxxxx
    
```

#### Display after the status display

- The LCD display shows the information Uncalibrated

```

YYYY.MM.DD      00:00
Not calibrated
Press start key
Battery status   93%
    
```

- The LCD display automatically changes to the registration window for language selection.

### 6.3 Language selection

```

[ Select language ]
English
Deutsch
Confirm
    
```

#### Note!

The corresponding language only needs to be selected here during the initial start-up.

1. Use the [arrow keys] to select the required language.
2. Confirm with the [multifunction key].
3. After confirming, the LCD display shows [Enter registration PIN].



## 6.4 Enter PIN code



### Note!

The factory-set PIN code only needs to be entered during the initial start-up.  
The factory-set PIN code is [0 0 0 0].

### Entering the factory-set PIN code



1. Use the corresponding [arrow keys] (1) or (2) to select the corresponding digits and confirm each one with the [multifunction key] (3).
2. Enter the next 3 required digits in the same way.
3. Following this, the LCD display shows the [Change PIN] dialog box.

## 6.5 Changing the PIN code



1. Enter a new PIN and repeat.
  2. Confirm the last entry with [multifunction key] (3)
- After this, the LCD display shows the [Date dialog box].

## 6.6 Setting/changing the date

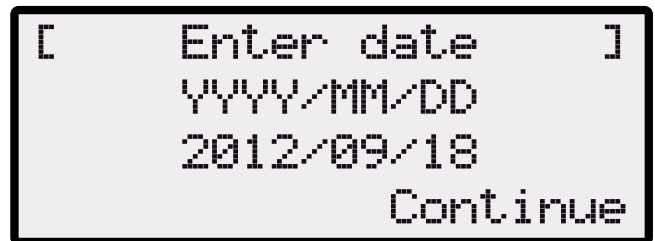

### Note!

Enter the date and time correctly, because further programming depends on the date and time.  
When entering the year (YYYY), it is only necessary to enter the last two digits because the first two 20XX are preset.

1. Use the corresponding [arrow keys] (1) or (2) to select the corresponding digits and confirm each one with the [multifunction key] (3).

After confirming, the LCD display shows [Time dialog box].

### 6.7 Setting/changing the time



1. Use the corresponding [arrow keys] (1) or (2) to select the corresponding digits and confirm each one with the [multifunction key] (3).

Following this, the LCD display shows the [Uncalibrated] status box.

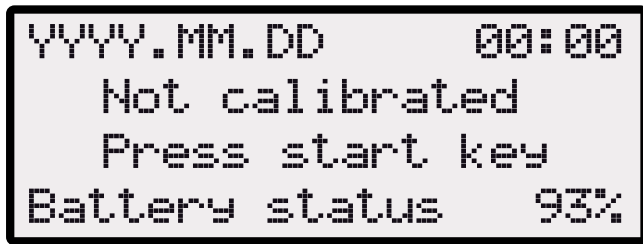

### 6.8 Calibration

**Note!**

For calibration, set up the robot lawnmower accordingly, see page 58.

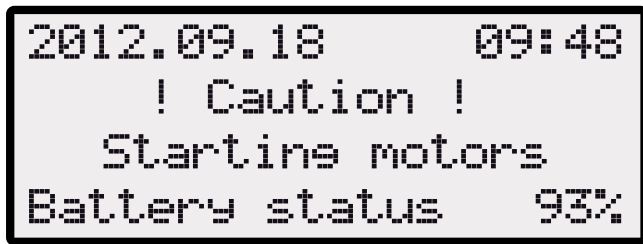

**Warning!**

The drive starts when the [START key] is pressed.

- Do not reach into rotating parts.

1. The automatic calibration procedure starts when the [START key] is pressed.

The [Drive starting] warning flashes on the LCD display.

### Calibration procedure starts

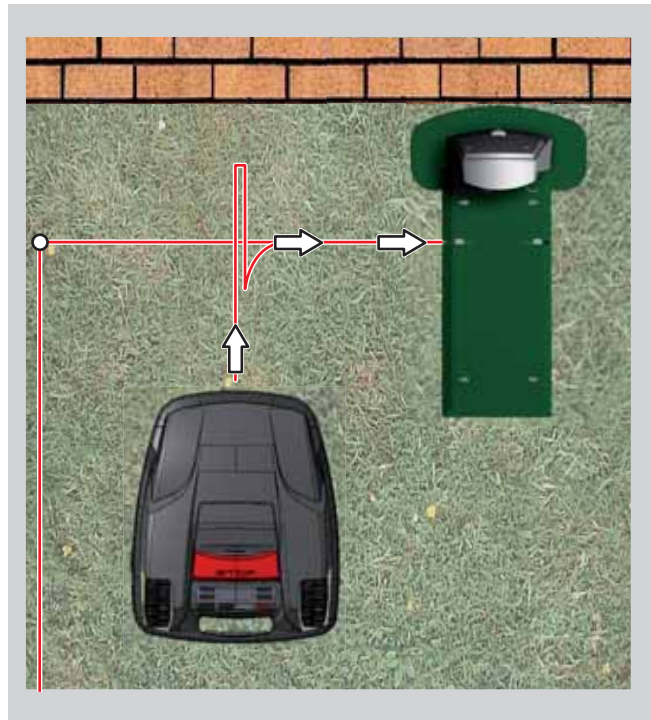
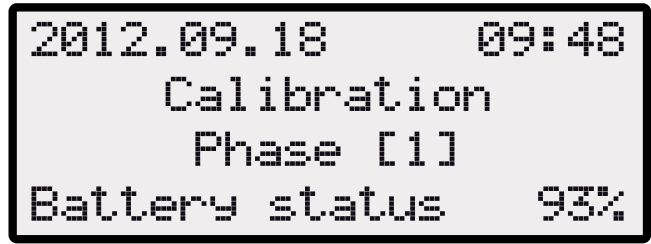

- The robot lawnmower first moves straight over the boundary cable in order to gauge the signal strength, and then into the base station.

**Note!**

The robot lawnmower must remain stopped when it moves into the base station. If the robot lawnmower does not meet the contacts when it moves into the base station, it will move further along the boundary cable until it meets the contacts or the procedure is cancelled.

- The battery of the robot lawnmower is charged.

## Display after the calibration movement

- After calibration has been completed, the robot lawnmower can be used for mowing with the factory-set mowing times without further programming.
- The mowing program is active, the battery is charged.
- The following mowing times are factory-set:  
Mon - Fri: 07:00 - 10:00 and Mon - Fri: 17:00 - 19:00



### WARNING!

**National regulations may place limits on the use of the machine.** Comply with any local bylaws imposing noise restrictions during certain hours of the day.

## Checking the cable laying

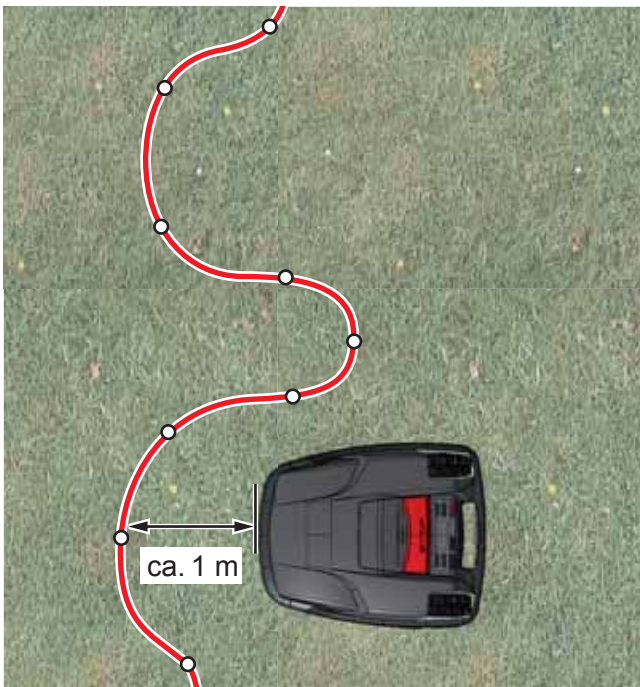

1. Place the robot lawnmower about 1 metre in front of the boundary cable.
2. Press the [HOME key], the robot lawnmower moves along the boundary cable back towards the base station.
3. In case of collisions or if the boundary cable is laid too close, the robot lawnmower will cancel its movement.
4. Rectify the error, place the robot lawnmower about 1 m in front of the boundary cable once again and press the [HOME key] a second time.

### Note!

Pressing the [HOME key] deactivates the mowing day. Pressing the [START key] activates the mowing day and starts the mowing procedure.

## 6.9 Starting the robot lawnmower

- Switch on the robot lawnmower by pressing the [ON/OFF key].



### Enter PIN code



- The PIN code must be entered at this point.

### Display next mowing

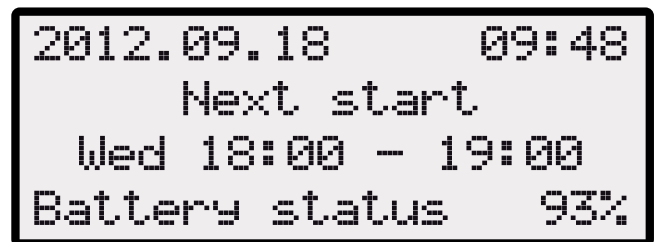

- After the PIN code has been entered, the [Next mowing] information appears. The robot lawnmower is now ready for mowing.
- The robot lawnmower starts automatically when the next mowing window is reached.
- Press the [START/PAUSE key] to start the mowing procedure immediately.

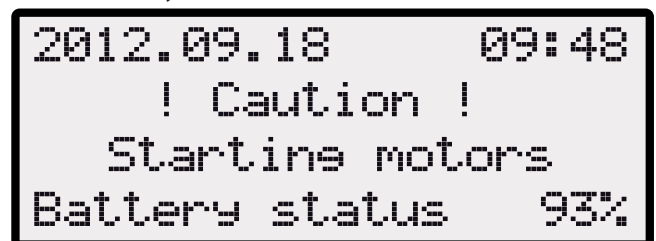

- The [Warning drive starting] display flashes and a signal sounds.

## 7 Mowing

### 7.1 Mowing tips

#### Note!

- To allow the performance of the robot lawnmower to be exploited to the full, we recommend having the robot lawnmower mow the lawn during cool times of the day or at night.



#### WARNING!

**National regulations may place limits on the use of the machine.** Comply with any local bylaws imposing noise restrictions during certain hours of the day.

- Cutting height at a constant 3 - 6 cm, do not mow off more than half of the lawn height.
- Adjust the mowing times accordingly.
- If the motor speed drops noticeably because of thick grass, increase the cutting height and mow in several passes.

### 7.2 Setting the cutting height



1. Press item (1). Cover (2) is unlocked and can be opened upwards.



#### Note!

- The cutting height varies in the range from 3 - 6 cm lawn height.
- The cutting height can be adjusted in five steps of 6 mm each.

1. Open lever (2) and turn it a quarter turn clockwise in the direction of [lock symbol opened] (1) (see also the quick info).
  - The cutting height adjustment is unlocked.
  - Pull lever (2) upwards: Lawn cutting height is increased.
  - Push lever (2) downwards: Lawn cutting height is reduced.
2. Cutting height adjustment is locked.
  - After cutting height adjustment:
    - Turn lever (2) a quarter turn anticlockwise in the direction of [lock symbol closed] (1) and engage.
3. Fold lever (2) down and close the cover.

### 7.3 Charging the battery in the robot lawnmower

#### Note!

- The integrated battery is partially charged on delivery.
- A lengthy charging period is not necessary, because the robot lawnmower can mow even when the battery is partially charged.
- When the charge level falls to 0% the robot lawnmower will automatically return to the base station to charge the battery.
- Interrupting charging does not damage the battery.
- The temperature range for charging should be between 0 and 40 °C.
- The built in protection circuit prevents the battery from being charged at temperatures above 45 °C, in order to prevent irreparable damage to the battery.
- If the operating time of the battery is reduced in spite of it being fully charged, have the battery replaced by a new genuine battery. This task should be carried out by an Authorised Service Centre.

- Recommendation: Place the base station in a shady location.





- The battery status is shown on the display (1).
- Make sure the charging contacts of the base station have adequate contact with the contact surfaces on the robot lawnmower.



#### **Warning!**

**Store the robot lawnmower indoors during the winter.**

- During normal operation, the battery of the robot lawnmower is regularly recharged.
- The base station is equipped with an electronic control unit with a monitoring function. This automatically terminates the charging procedure when a 100% charge status is reached.
- Before putting the robot lawnmower into storage for the winter, please make sure it is fully charged.
- After 3 months of storage check the battery status; switch on the robot lawnmower and read the battery charge level. If necessary, place it in the base station for charging.
- Once the battery is fully recharged, put the robot lawnmower back into store.

## **7.4 Exhaustively discharged battery**

- If the battery charge level has dropped below the threshold set by the manufacturer as a result of ageing or excessively long storage, this means it cannot be recharged any longer.
- Have the battery and the monitoring electronic control unit checked by an Authorised Service Centre, and renew it if necessary.



#### **Warning!**

**Do not attempt to carry out any kind of work on the battery.**

## 8 Programming

### 8.1 Starting the robot lawnmower

#### Note!

In order to access the program menus of the robot lawnmower, it is necessary to perform this start procedure in all cases.

- If necessary, switch on the robot lawnmower by pressing the [ON/OFF key] (1), then enter the PIN code.
- After switch-on, information is given regarding the next mowing.

```
2012.09.18      09:48
Next start
Wed 18:00 - 19:00
Battery status  93%
```

#### Note!

The displayed mowing operation may be the factory setting, unless a new mowing operation has already been programmed.

#### Note!

The PIN code may also be the factory code if no different code was entered during calibration.

- After the PIN code has been entered, the [Next mowing] information appears again.
- The robot lawnmower is now ready for the programs and settings to be selected.

### Selecting the menu



- After switching on, it is possible to call up the main menu with the [menu key] (1).

## 8.2 Overview

■ The main menu of the robot lawnmower is divided up into the following submenus:

- Program menu.
- Setting menu.
- Information menu.

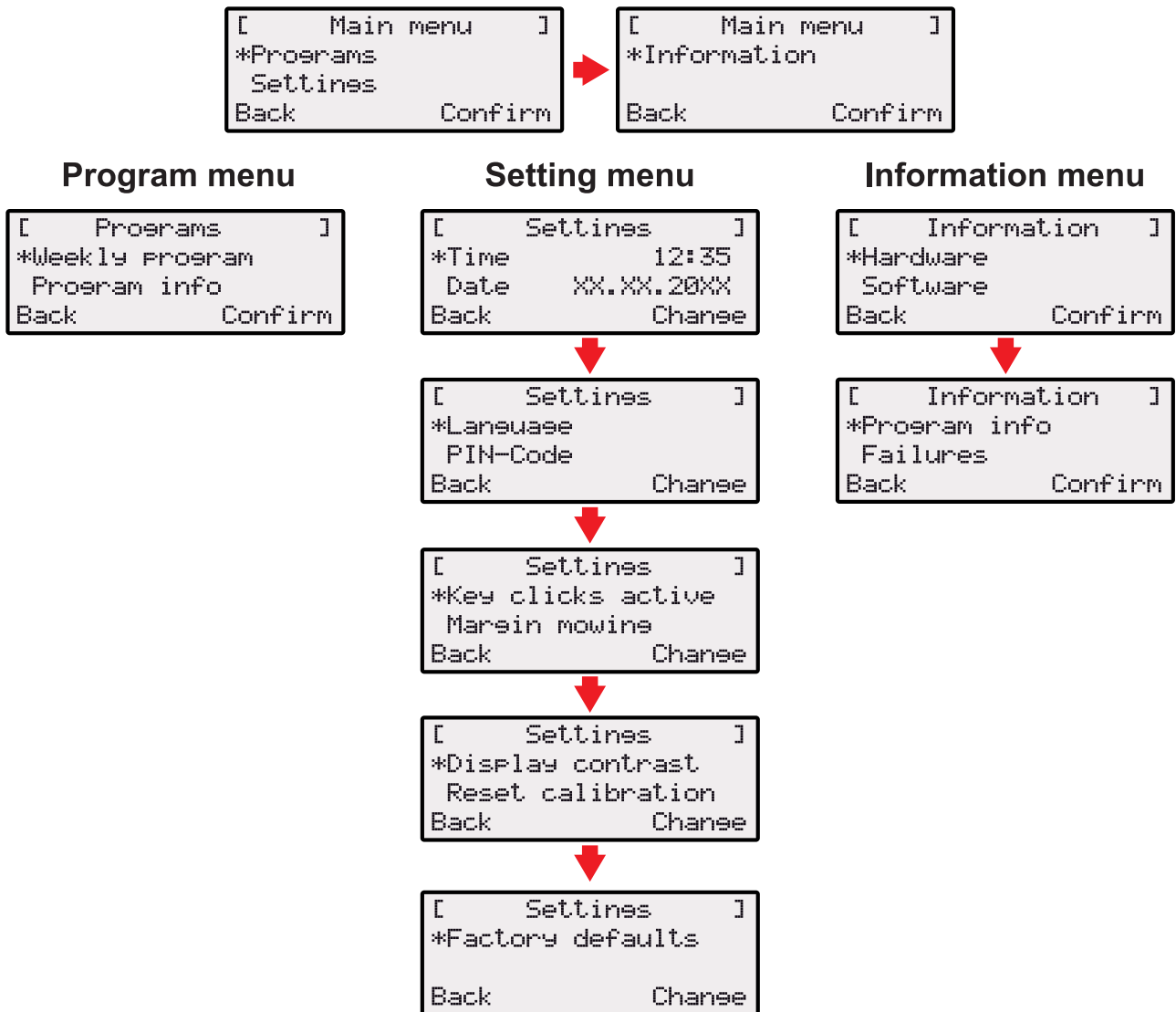

### Note!

- Start the robot lawnmower as described.
- Use the [up arrow key] or the [down arrow key] to select the required main menu.
- The star symbol to the left of the menu displays shows which selection is active.
- Confirm the required main menu with the [multifunction key right]. The corresponding sub-menus open.
- Confirm the required application with the [multifunction key right]. Change the sub-menu items if required.
- Use the [multifunction key left] to return to the standard display.

## 9 Program menu

### Note!

Description of function keys, see page 43.

- Make the settings in the week program.
- Look at the program info, e.g. mowing program.

### Selecting the program

- Before programming, it is necessary to perform the start procedure, see page 64.

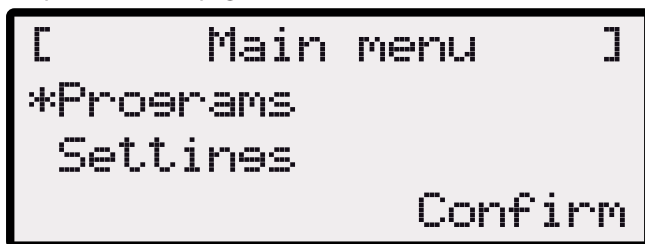

1. Use the [up arrow key] or the [down arrow key] to select the Programs menu item.
2. Confirm with the [multifunction key right].
3. Select the required programs and confirm with the [multifunction key right].

- The symbol [X] shows the currently active day of the week.

### 9.1 Setting the week program

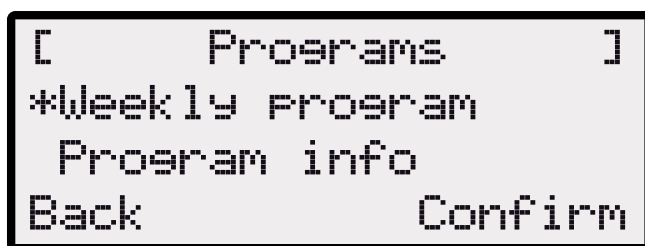

1. In the week program, the days of the week (2) and the times are set when the robot lawnmower should mow automatically.
2. In the [All days] menu item (1), the robot lawnmower mows at the set times every day.
3. Observe the mowing result and mow as long as necessary in order to obtain a well kept lawn.
4. Use the corresponding [arrow keys] to select the required menu point and confirm with the [multifunction key right] in each case.

### Mowing time setting in batch mode

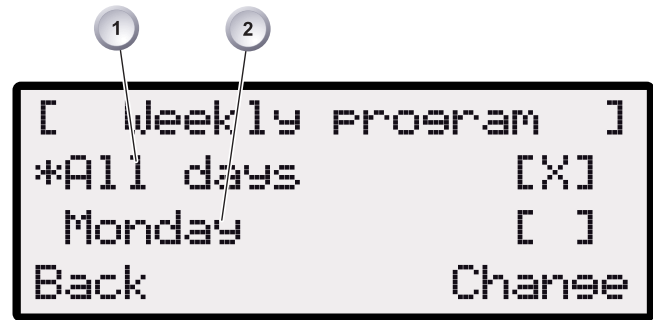

1. Select the required menu item, [Every day], with the [arrow keys] and confirm with the [multifunction key right].
2. Press the [down arrow key] until [Change] is active.

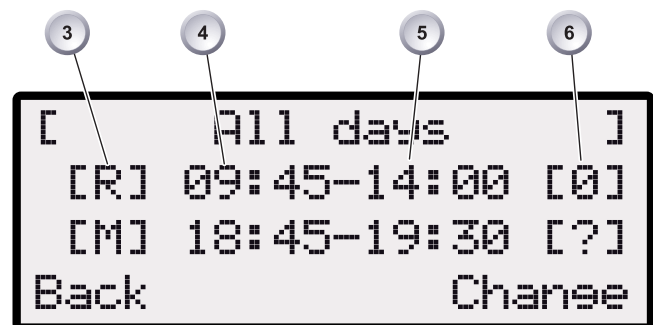

1. Select the required menu item with the [arrow keys] and confirm with the [multifunction key right].

### Explanation of symbols:

- (3) [-] Mowing window deactivated.
- (3) [R] Edge mowing.
  - The robot lawnmower mows left and right along the boundary cable. After mowing the edges, the robot lawnmower continues mowing the marked-out area
  - [M] Normal mowing
  - The robot lawnmower mows the entire area marked out by the boundary cable
- (4) Start time
  - The robot lawnmower departs from the base station at the selected time for mowing.
- (5) End time
  - The robot lawnmower moves back to the base station at the selected time.
- (6) [0 - 9] Fixed entry point
  - The robot lawnmower departs from the selected entry point at the selected time for mowing. The start points are set automatically and cannot be modified.
  - [?] Automatic entry point
    - The start points are set automatically and cannot be modified.

## 10 Setting menu

- Set the time.
- Set the date.
- Set the language.
- Changing the PIN code
- Set the button tones.
- Activate or deactivate the margin moving.
- Set the display contrast.
- Reset calibration.
- Restore factory settings

### 10.1 Setting the time

#### Selecting the program

- Before programming, it is necessary to perform the start procedure (see page 64).

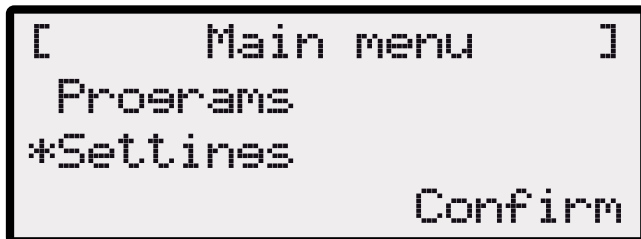

1. Use the [up arrow key] or the [down arrow key] to select the [Settings] menu item.
2. Call up the [Time] menu.
3. Confirm with the [multifunction key right].



#### Note!

When setting the time, it is necessary to select each individual digit until it flashes.  
Enter the time correctly, because further programming depends on the time.  
Confirm individual digits and use the arrow keys to select the next digit.

- The time is displayed in 24-hour format.

1. Select the required time with the [arrow keys] and confirm with the [multifunction key right].

- Exit setup mode by pressing the [Menu key] twice.

### 10.2 Setting the date

#### Selecting the program

- Before programming, it is necessary to perform the start procedure (see page 64).

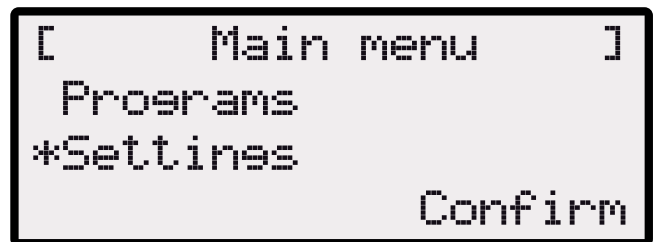

1. Select the required program item with the [arrow keys] and confirm with the [multifunction key right].
2. Call up the [Date] menu.

#### Setting the date



#### Note!

Enter the date correctly, because further programming depends on the date.  
When entering the year (YYYY), it is only necessary to enter the last two digits because the first two 20XX are preset.

- The date display is structured as follows:

- DD for the day.
- MM for the month.
- YYYY for the year.

1. Press the [up arrow key] briefly once. A [0] flashes at the first place in the display, or press the [arrow key] (2) once briefly. A [9] flashes at the first place in the display.
  2. Either use the [down arrow key] to count down from [9] or use the [arrow key] to count up until the required digit is displayed.
  3. Confirm with the [multifunction key right].
  4. Enter the next required digits in the same way until the date has been fully set.
  5. Confirm with the [multifunction key right].
- Exit setup mode by pressing the [Menu key] twice.

### 10.3 Setting the language

- Before programming, it is necessary to perform the start procedure (see page 64).

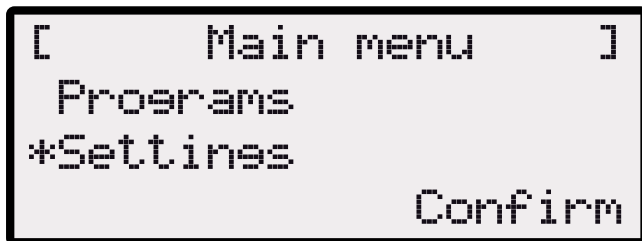

1. Use the [up arrow key] or the [down arrow key] to select the [Settings] menu item.
2. Call up the required menu, [Language].
3. Confirm with the [multifunction key right].

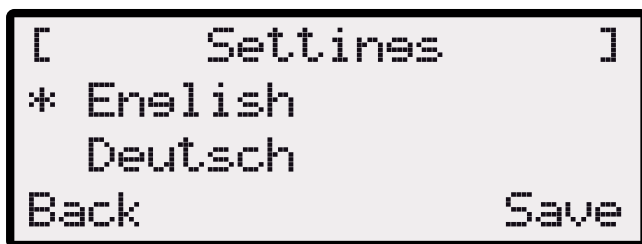

#### Note!

The corresponding language only needs to be selected here during the initial start-up.

1. Use the [arrow keys] to select the required language.
2. Confirm with the [multifunction key].
3. After confirming, the LCD display shows [Enter registration PIN].

### 10.4 Further setting possibilities

#### Note!

All other setting possibilities are always called up in the same way.

- After switching on, it is possible to call up the corresponding program menu with the [menu key].

1. Select the [Settings] menu in the main menu.

### 10.5 Activate or deactivate the button tones

- Before programming, it is necessary to perform the start procedure, see page 64.

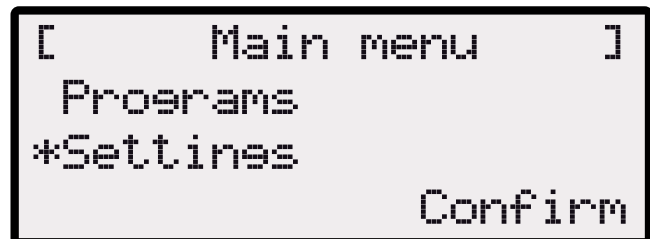

1. Use the [up arrow key] or the [down arrow key] to select the [Settings] menu item.
  2. Call up the required menu, [Button tones].
  3. Confirm with the [multifunction key right].
  4. Activate or deactivate the button tones with the [multifunction key right].
- Exit setup mode by pressing the [Menu key] twice.

## 10.6 Changing the display contrast on the LCD display

- 1 In the Settings sub-menu, select [Display contrast].
  - 2 Select [Display contrast] with the [arrow keys] and confirm with the [multifunction key right].
- Exit setup mode by pressing the [Menu key] twice.

## 10.7 Restoring factory settings

- 1 In the Settings sub-menu, select [Factory settings].
  - 2 Enter the PIN code again and confirm.
- Exit setup mode by pressing the [Menu key] twice.

## 11 Information menu

- Hardware information comprising, e.g.:
  - Product name.
  - Year of manufacture.
  - Number of operating hours.
  - Serial number.
  - Distance covered.
  - Software status with version number.

### Note!

- The Information menu is used for calling up various information such as software status, hardware status and current settings.
- No settings can be made in this menu.

### Selecting the program

- Before programming, it is necessary to perform the start procedure, see Starting the robot lawnmower on page 64.

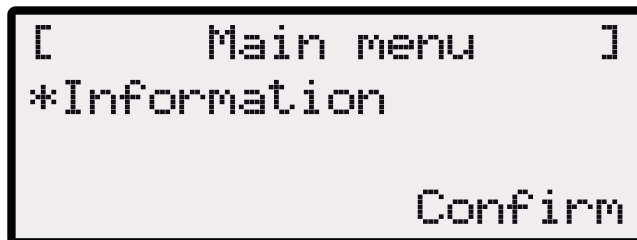

1. Use the [up arrow key] or the [down arrow key] to select the [Information] menu item and confirm with the [multifunction key right].

### 11.1 Hardware information

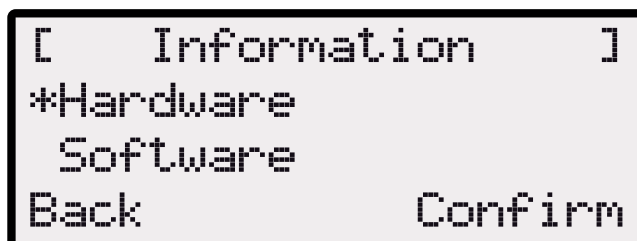

1. Use the [up arrow key] or the [down arrow key] to select the [Hardware or software] menu item.
2. Confirm with the [multifunction key right].
3. Call up the corresponding hardware or software information.
4. Use the [multifunction key left] to return to the main menu.

## Hardware

```
[ Hardware ]
Emak Robomower
Fabrication XXXXXXXX
Back
```

- The unit's identification data will be displayed: name, production date, operating hours, serial number, cutting cycles, charging cycles, charging hours and perimeter of the boundary cable.

### 11.2 Software information

```
[ Software ]
Version XXXXXXXXXXXX
Back
```

- The version number of the software is displayed.

## 12 Program information

- Total weekly mowing time.

```
[ Program info ]
Total weekly
Mowing time 0:00
Back
```

- The total set number of mowing hours is displayed.

- Times per programming, the day of the week and the time when mowing takes place.

```
[ Program info ]
Sun: 10:00 - 14:00
Sun: 18:00 - 19:00
Back
```

- The total set mowing time in the week is displayed.

## 13 Transport



- When transporting within the mowing area:
  - 1 Stop the robot lawnmower using [STOP key] (2).
  - 2 Switch off robot lawnmower at [ON/OFF key] (1).



### Caution!

#### Injuries due to the cutting blades!

- The blades will come to a stop in 2 seconds!
- Make sure the cutting blade plate is pointing away from your body.



- 3 Only carry the robot lawnmower by its handle (1).



## 14 Maintenance



### Warning!

#### Injuries due to the cutting blades!

- Always switch off the robot lawnmower at the [ON/OFF key] before starting maintenance and repair work.
- Always wear working gloves when carrying out maintenance and care jobs on the blade system.
- Disconnect the transformer of the base station from the mains.



### Important!

#### Damage to the electrical/electronic system by incorrect cleaning!

- Do not clean the robot lawnmower with a high-pressure cleaner or under running water. Water penetration can cause irreparable damage to the switch, battery and circuit boards.

- Entrust all repairs (apart from replacement of the blades) to specialist workshops approved by the manufacturer.

#### The user is under obligation:

1. To bring the robot mower to the workshop after between 100 and 200 hours operation, for:
  - Check on tightness of bolts
  - General check on programming and detection of possible errors
2. To bring the robot mower to the workshop after 500 and 2500 hours operation, for:
  - General check on tightness of bolts and mechanical parts
  - Check on error statistics
  - Check on battery status
  - Check on wheel bearings
  - Inspection of blade and check for possible damage
  - General inspection and cleaning

#### Operations to be carried out periodically by the user

- Once a week, clean the robot lawnmower thoroughly with a hand brush or a cloth, and use care spray if necessary. Contamination can impair the function of the machine if not removed.
- Once a week, check the cutting blades for damage.

### 14.1 Check the rollers can move freely



- 1 Once a week, thoroughly clean the area around the rollers (1) with a hand brush or cloth.
- 2 Check the rollers (1) can move and steer freely. If the rollers (1) do not move freely, they must be freed up or renewed.

### 14.2 Checking/cleaning contacts



- Check the contact surfaces (1) on the robot lawnmower for contamination.
- Clean the contact surfaces (1) on the robot lawnmower with a cloth if necessary.
- Charring on the contact surfaces indicates a poor charging contact.
  - Bend the springs on the base station outwards.

### 14.3 Checking/cleaning the base station

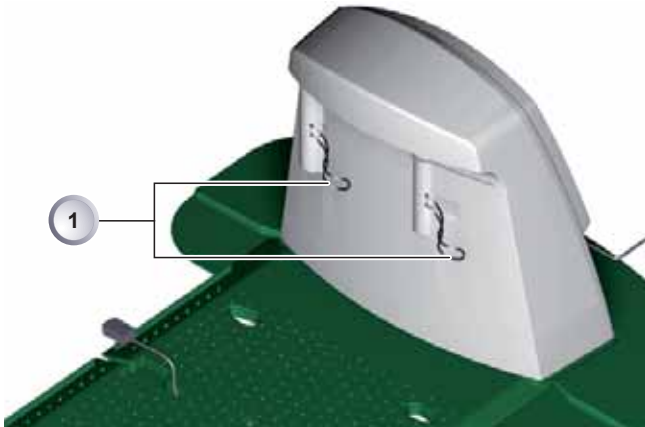

- 1 Disconnect the transformer mains plug.
- 2 Check the contacts (1) on the base station for contamination.
- 3 Clean the contacts (1) on the base station using a cloth if necessary.
- 4 Push the contacts (1) towards the base station and release. The contacts (1) must spring back into the initial position.
- 5 If the contacts (1) do not spring back into the initial system, have them checked by an Authorised Service Centre, and renewed if necessary.

### 14.4 Cleaning the chassis



- Thoroughly clean grass catcher (1) and guide (2) using a hand brush or a cloth.

## 15 Repair



### Warning!

#### Injuries due to the cutting blades!

- Switch off the robot lawnmower at the [ON/OFF key] before starting maintenance and repair work.
- Always wear working gloves when carrying out maintenance and care jobs on the blade system.
- Disconnect the transformer of the base station from the mains.



### Important!

#### Damage due to an incorrect repair!

- Never repair damaged cutting attachments by welding, straightening or modifying the shape. This may cause parts of the cutting tool to come off and result in serious or fatal injuries.

### 15.1 Renewing the cutting blade plate



- 1 Place the robot lawnmower with the cutting blades (3) pointing upwards.
- 2 Hold cutting blade plate (2) firmly.
- 3 Unscrew and remove three screws (1).
- 4 Pull off cutting blade plate (2) with the cutting blades (3).
- 5 Put on cutting blade plate (2) with the cutting blades (3).
- 6 Brace cutting blade plate (2) firmly.
- 7 Screw in and tighten new screws (1).

## Renewing the transformer fuse



### Warning!

**Danger of fire due to fitting an incorrect fuse or jumpering the fuse.**

- Always use a fuse with the same amp rating.
- Never jumper the fuse.

- 1 Disconnect the transformer mains plug.
- 2 Using a flat-blade screwdriver, carefully press in bayonet lock (1) at the same time as opening anticlockwise. Bayonet lock (1) springs out slightly.
- 3 Renew the fuse and close bayonet lock (1) by turning clockwise with the flat-blade screwdriver.

## 16 Technical data

<b>Data robot lawnmower</b>	
Length in mm	600
Width in mm	490
Height in mm	245
Weight in kg	approx. 8
Mowing system	Electric with 2 cutting blades
Cutting blade motor rpm	3400
Cutting heights in mm	30 - 60
Cutting height adjustment 5-stage in mm	6 mm per stage
Cutting width in mm	280
Max. lawn to be mown in m <sup>2</sup>	approx. 700
Max. slope of the lawn in %	35
Distance from boundary cable to boundary line (wall/hedge)	approx. 20 cm
<b>Data of base station/transformer</b>	
Base station power input voltage	230 V / 16 A / 50 Hz
Secondary voltage/current/wattage	27 V AC / 2,2 A / 60 VA
<b>Noise emissions</b>	
Measured volume in dB(A)	63
Guaranteed volume in dB(A)	69
<b>Battery</b>	
Voltage in V	18
Capacity in Ah	1,5
Energy in Wh	27
Maximum charging temperature in degrees Celsius	40 °C

## 17 Help in case of malfunctions

### 17.1 Examples of fault messages

#### Note!

- The battery and mowing motor in the robot lawnmower are monitored by an electronic control unit, which displays malfunctions and the status on the LCD display of the robot lawnmower.

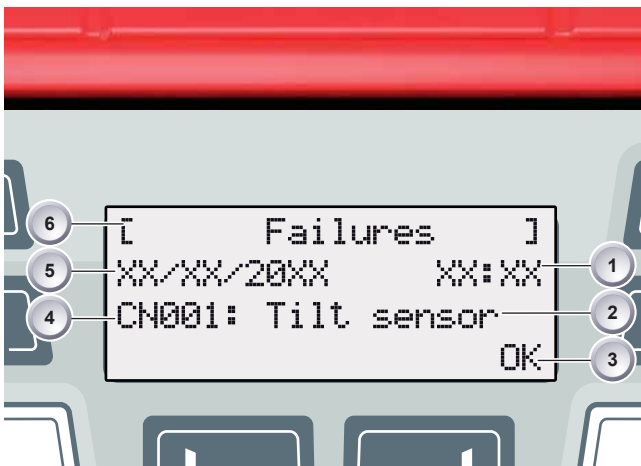

- |   |                 |   |                     |
|---|-----------------|---|---------------------|
| 1 | Time            | 4 | Fault code          |
| 2 | Fault message   | 5 | Date                |
| 3 | Actuation panel | 6 | Malfunction display |

#### Note!

If this display reappears, do not continue operation. Have the robot lawnmower checked by an Authorised Service Centre

## 17.2 Troubleshooting

If your robot lawnmower does not function correctly, follow the recommendations below. If the fault is not listed here or you cannot identify it, contact an Authorised Service Centre for help with troubleshooting.

<b>Fault messages</b>	<b>Possible cause</b>	<b>Measure</b>	
<b>Low battery voltage</b>	Boundary cable defective, robot lawnmower does not find the base station.	Check the boundary cable for interruptions, if necessary have it tested by an Authorised Service Centre.	
	Battery exhausted.	The battery has exceeded its service life. Have the battery renewed by an Authorised Service Centre.	
	Charging electronic control unit defective.	Have the electronic control unit checked by an Authorised Service Centre. Have the battery renewed.	
	The robot lawnmower does not touch the charging contacts.	Push the robot lawnmower into the base station and check if the charging contacts make contact.  Have the spring mechanism or the charging contacts checked by an Authorised Service Centre.  Have bent or broken charging contacts renewed by an Authorised Service Centre.	
<b>Incorrect PIN code</b>	The wrong PIN code was entered.	Enter the right PIN code. Three attempts are possible, after which a PUK code must be entered.	
<b>Uneven mowing result.</b>	Working time of the robot lawnmower is too short.	Program longer working times.	
	Mowing area too large.	Program longer working times. Reduce the mowing area.	
	The cutting height is not correct for the length of the grass (long grass).	Raise the cutting height The gradually reduce the cutting height until reaching the required height.	
	The cutting blades are blunt.	Renew the cutting blades and the corresponding screws.  Have the cutting blade resharpened by an Authorised Service Centre and reinstall it with new screws.	
	Grass is blocking or hampering the rotation of the cutting blade plate or motor shaft.	Remove the grass and make sure that the cutting blade plate can then rotate freely.  If the cutting blade plate still does not rotate freely, remove the cutting blade plate, clean it and reinstall it with new screws.	
	<b>The robot lawnmower mows at the wrong time.</b>	The time on the robot lawnmower must be set.	Set the time, see Changing the time on page 60.
		Start and finish times of mowing have been entered wrongly.	Set the start and finish times again, see Changing the time on page 66.
<b>The robot lawnmower vibrates.</b>	Imbalance on the cutting blade or cutting blade drive.	Check the cutting blade and cutting blade drive and renew if necessary.	

## Error message

Error message	Possible cause	Solution
<b>CN001: Tilt sensor</b>	<ul style="list-style-type: none"> <li>• Maximum gradient exceeded</li> <li>• Excessively steep slope</li> </ul>	Exclude the excessively steep slope from the cutting area
	Robot has been picked up	Place the robot on a level surface and reset the error.
<b>CN002: Lift sensor</b>	The housing has been displaced in an upward direction because it has been lifted or because the mower has run over an object.	Remove the foreign object.
<b>CN005: Bumper deflected</b>	The robot has collided with an obstacle and is unable to move clear (collision near the base station).	Remove the obstacle
<b>CN007: No loop signal</b> <b>CN017: Cal: signal weak</b>	No circuit signal. Error during calibration, circuit signal too weak.	<ul style="list-style-type: none"> <li>• Check base station power supply.</li> <li>• Check circuit.</li> <li>• Disconnect and then reconnect the transformer.</li> </ul>
<b>CN008: Loop signal weak</b>	Circuit signal is weak.	<ul style="list-style-type: none"> <li>• Check base station power supply.</li> <li>• Check boundary circuit: the cable may be buried too deep.</li> <li>• Disconnect and then reconnect the transformer.</li> </ul>
<b>CN010: Bad position</b>	The robot has moved outside the operating area.	<ul style="list-style-type: none"> <li>• Return the robot to the operating area.</li> <li>• Boundary cable crossover</li> </ul>
<b>CN011: Escaped robot</b>	The robot has moved outside the operating area.	Check laying of the boundary cable (curves, obstacles, etc.).
<b>CN012: Cal: no loop</b> <b>CN015: Cal: outside</b>	Error during calibration: the robot has not detected the circuit.	<ul style="list-style-type: none"> <li>• Position the robot at right angles with respect to the boundary cable; the robot must be able to straddle the boundary cable.</li> <li>• Check base station power supply.</li> <li>• Check circuit.</li> <li>• Disconnect and then reconnect the transformer.</li> <li>• Boundary cable crossover.</li> </ul>
<b>CN018: Cal: Impact</b>	Error during calibration, impact	Remove the obstacle.
<b>CN038: Battery</b>	Battery discharged.	<ul style="list-style-type: none"> <li>• Check that there are no obstacles preventing the robot from docking at the base station.</li> <li>• Check the electrical charging contacts of the base station.</li> <li>• Circuit is too long or has too many islands.</li> <li>• The robot lawnmower has become stuck.</li> </ul>
	Defective boundary cable, the robot is unable to find the base station.	Check the boundary cable for possible breaks, if necessary have the circuit tested by an authorized service centre
	Spent battery.	The battery has reached the end of its working life. Contact an authorized service centre to fit a new battery
	Charging circuit electronics faulty.	Contact an authorized service centre to replace the charging circuit board
	Robot does not connect with the charging contacts.	<ul style="list-style-type: none"> <li>• Return the robot to the base station and ensure the charging contacts are connected.</li> <li>• Have the charging contacts checked and, if necessary, replaced by an authorized service centre</li> </ul>

Error message	Possible cause	Solution
<b>CN099: Recov escape</b>	Error cannot be cleared automatically	Clear the error manually
	The robot has moved outside the operating area	Return the robot lawnmower to the base station.
<b>CN104: Battery over heating</b>	Battery overheating – battery temperature has exceeded 60°; battery cannot discharge	Electronic controller performs emergency shut-down procedure. Do not position the robot on the base station. Switch off the robot and allow the battery to cool down.
<b>CN110: Blade motor over heating</b>	Robot lawnmower motor is overheating, temperature > 80°C.	Switch off the robot and allow it to cool down. If the problem recurs have the robot checked by an authorized service centre
<b>CN119: R-Bumper deflected</b> <b>CN120: L-Bumper deflected</b>	The robot has collided with an obstacle and is unable to break free for reasons of safety, e.g. collisions that occur too close to the base station.	Remove the obstacle and reset the error message.
<b>CN125: Bumper escape</b>	When reversing after colliding with an obstacle the robot has moved outside the operating area.	The housing is jammed or the bumper is faulty; remove the obstacle
<b>CN128: Recov Impossible</b>	Collision with an obstacle or escape from circuit -> reversing impossible, the robot is unable to break free.	Remove the obstacle and make sure the robot housing is correctly positioned
<b>CN129: Blocked WL</b>	Left-hand drive wheel jammed	Remove obstruction
<b>CN130: Blocked WR</b>	Right-hand drive wheel jammed	Remove obstruction

### 17.3 Interactive help

- For interactive programming help, it is possible to scan in a QR code, e.g. using a smartphone.
- To do this, it is necessary to have an app that can be downloaded from the smartphone's manufacturer. This service may incur charges, depending on the network provider.

- Following this, you will be redirected to the selected website for the topic in question.
- Customers who cannot use the QR code can access the support address at <http://www.efco.it>.
- Costs of using the link or the QR code depend on the mobile phone network provider.

## 18 Warranty certificate

This machine has been designed and manufactured using the most modern techniques. The company guarantees its products for a period of 24 months from the original date of purchase.

### Limited warranty

- 1) The warranty period starts on the date of purchase. The manufacturer, acting through the sales and technical assistance network, shall replace free of charge any parts proven defective in material, machining or manufacturing. The warranty does not affect the purchaser's rights as established under legislation governing the consequences of defects in the machine.
- 2) Technical personnel will undertake the necessary repairs in the minimum time possible, compatible with organisational needs.
- 3) **To make any claim under the warranty, this certificate of warranty, fully completed, bearing the dealer's stamp and accompanied by the invoice or receipt showing the date of purchase, must be displayed to the personnel authorised to approve work.**
- 4) The warranty shall be null and void if:
  - the machine has evidently not been serviced correctly

- the machine has been used for improper purposes or has been modified in any way,
  - non-original spare parts and accessories have been fitted
  - work has been done on the machine by unauthorised personnel
- 5) The warranty does not cover consumables or parts subject to normal wear (batteries, blades, cables, connectors, etc...).
  - 6) The battery warranty is limited only to manufacturing defects during the first starting of the product.
  - 7) The warranty does not cover work to update or improve the machine.
  - 8) The warranty does not cover any preparation or servicing work required during the warranty period.
  - 9) Damage incurred during transport must be immediately brought to the attention of the carrier: failure to do so shall render the warranty null and void.
  - 10) The warranty does not cover damage to paintwork associated with normal wear.
  - 11) The warranty does not cover injury or damage caused directly or indirectly to persons or things by defects in the machine or by periods of extended disuse of the machine resulting from the said defects.

MODEL \_\_\_\_\_

\_\_\_\_\_

**SERIAL No** \_\_\_\_\_

BOUGHT BY Mr. \_\_\_\_\_

\_\_\_\_\_

\_\_\_\_\_

\_\_\_\_\_

DATE \_\_\_\_\_

\_\_\_\_\_

DEALER

**Do not send! Only attach to requests for technical warranties.**



## 19 Disposal



### Environmental pollution!

The robot lawnmower, its batteries and electronic components must not be disposed of in the domestic waste at the end of their life.

- Dispose of in accordance with local regulations.



In accordance with Directives 2002/95/CE, 2002/96/CE and 2003/108/CE on the reduction of hazardous substances in electrical and electronic equipment (ROHS) and the disposal of waste from such equipment (WEEE)

When the symbol depicting a crossed-out refuse bin appears on equipment, this means that it **must** be collected separately from other waste at the end of its working life.

When the equipment is no longer serviceable, accordingly, it should be taken by the user to a special sorted collection centre for electrical and electronic waste, or if purchasing a **new product of similar type, returned to the dealer on a one-for-one basis (takeback scheme).**

Proper sorted collection ensures that the discarded equipment can be sent subsequently for eco-friendly recycling, treatment and disposal; this helps to avoid any possible negative impact on the environment and on health, besides enabling the reclamation of materials used in manufacturing the equipment.

Unauthorized dumping of waste is irresponsible, and punishable under statutory regulations.

### Note!

- The battery has been tested according to the UN handbook. Therefore, the battery is not subject to national and international regulations governing substances of concern, whether it is an individual part or has been installed in the robot lawnmower.
- Do not dispose of the battery unless it is discharged.
- A defective or spent battery must be returned by the user.
- **WARNING!** Ensure the appliance is rendered unusable before handing over for disposal. To avoid accidents, remove the safety connector and the motor power cable.

## 20 Declaration of conformity

The undersigned, **Emak spa via Fermi, 4 - 42011 Bagnolo in Piano (RE) ITALY** declares under its own responsibility that the machine:

1. Category: robot lawnmower
  2. Brand Efco, Type Sirius 700
  3. Serial ID 652 XXX 0001 ÷ 652 XXX 9999
- conforms to the requirements of Directives: 2006/42/EC - 2004/108/EC,  
conforms to the provisions of the following harmonised standards:  
EN 60335-1 / IEC 60335-2-107 / EN 55014-1 / EN 55014-2 / EN 61000-3-2 / EN 61000-3-3 / EN 61000-3-3/A1  
Type of cutting device: rotary blade.  
Cutting width: 28 cm  
Technical Documentation deposited with Administrative Headquarters: Technical Department

Signed in Bagnolo in Piano (RE) Italy - via Fermi, 4  
Date: 01/09/2013

  **Emak**<sup>®</sup> s.p.a.

Fausto Bellamico - President

The undersigned, **Emak spa via Fermi, 4 - 42011 Bagnolo in Piano (RE) ITALY** declares under its own responsibility that the machine:

1. Category: Current transformer
  2. Brand Ulmer Trasformatorenbau, Type single-phase power supply NTEV60
- conforms to the requirements of Directives: 2006/95/CE,  
conforms to the provisions of the following harmonised standards: 60335-2-29  
Technical Documentation deposited with Administrative Headquarters: Technical Department

Signed in Bagnolo in Piano (RE) Italy - via Fermi, 4  
Date: 01/09/2013

  **Emak**<sup>®</sup> s.p.a.

Fausto Bellamico - President

**I** **ATTENZIONE!** – Questo manuale deve accompagnare la macchina durante tutta la sua vita.

**GB** **WARNING!** – This owner's manual must stay with the machine for all its life.



It's an **EMAK S.p.A.** trademark  
42011 Bagnolo in Piano (RE) Italy  
Tel. +39 0522 956611 • Fax +39 0522 951555  
service@emak.it • www.efco.it

*We care*

*Quality Ethics Environment*  
ISO 9001 - SA 8000 - ISO 14001